

## DH PLATE LOADED SERIES

## DH058 - MULTI-SQUAT LUNGE

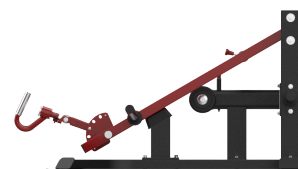
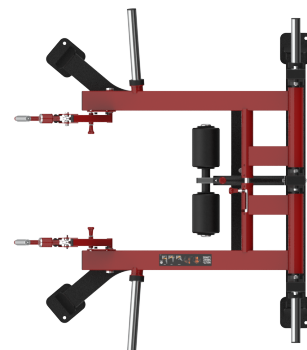

## PRODUCT OVERVIEW

The DH058 is a plate-loaded training machine designed specifically for lower-body development. Featuring a modern aesthetic and robust structure, it is ideal for large commercial gyms and high-end personal training studios. This versatile machine integrates multiple classic lower-body movements including Bulgarian split squats, deadlifts, and lunges offering diverse training options within a compact footprint.

A five-position rotating U-shaped handle provides secure, anti-slip grip options, adapting flexibly to different grip widths and training habits to improve both comfort and efficiency. A ten-position adjustable support pad ensures stable leg support, accommodating users of varying heights and leg lengths to help them establish the ideal starting position for effective performance. Combined with multiple handle height adjustments, it allows movements to flow more smoothly and naturally.

The independently adjustable movement arms enable unilateral training, enhancing movement control and improving both core and joint stability for more precise, efficient training. Built with high-strength steel tubing, the machine ensures reliable performance and long-term stability, even under high-frequency, intensive use.

# SPECIFICATIONS & KEY FEATURES

## Specifications

Dimension:	1520*1729*826mm
Net Weight:	110kg
Max Load Capacity:	300kg[2x150kg]
Main Frame Tubing:	J50x100x2.5
Target Muscle Groups:	Gluteus Maximus, Hamstrings, Quadriceps
Standard Color Scheme:	DH Series standard color scheme

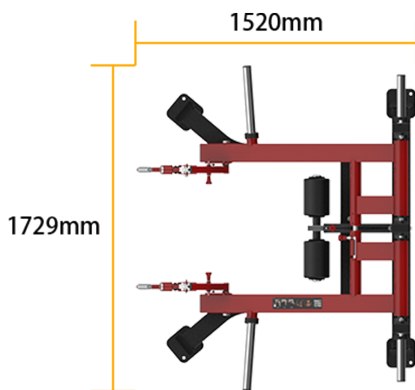
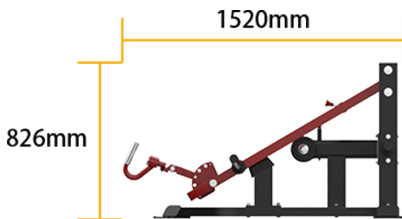
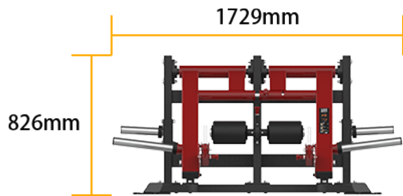

## Product Features



### Heavy-Duty Structural Design

Constructed from high-strength steel tubing, ensuring stability and reliability during high-intensity training with no shaking or shifting.

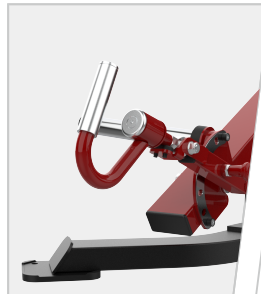

### Five-Position Rotating U-Shaped Handles

Anti-slip rubber-coated grips adapt to a wide range of grip widths and styles, meeting diverse training needs while maintaining comfort and control.



### Ten-Position Adjustable Support Pad

Provides secure and comfortable leg support, accommodating different heights and leg lengths for smoother movements and more focused force application.



### Independent Movement Arm System

Allows unilateral loading, improving movement control and strengthening both core and joint stability, delivering more targeted training outcomes.



### Ergonomic Adjustment Options

Multiple adjustment points for handles and support components help users quickly find their optimal training position, enhancing both performance and safety.